



# Complete Specification Sheet

## CH-725

CHANNEL

### Channel 725

Extruded Aluminum Mounting Channel

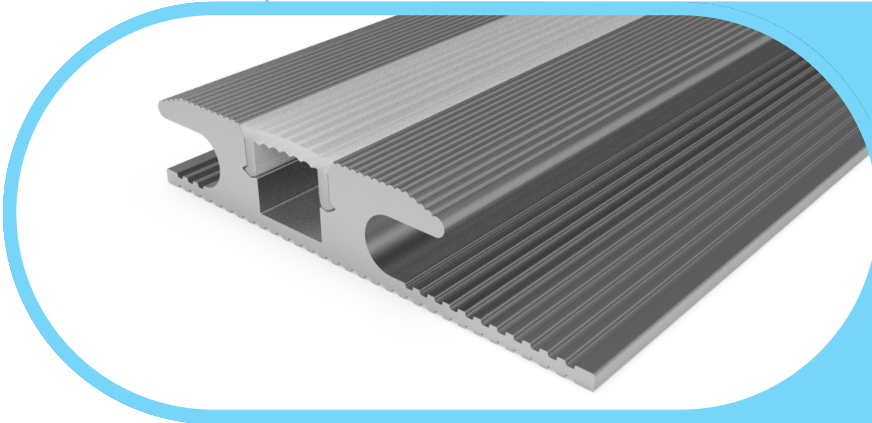

#### Specifications

<b>Category</b>	Rigid Channel
<b>Series</b>	Aisles
<b>Family</b>	CH-725
<b>Width</b>	2.50in (63.5mm)
<b>Internal Width</b>	0.40in (10.2mm)
<b>Height</b>	0.50in (12.7mm)
<b>Material</b>	Aluminum

#### Features

- Available in 2 Meter Sections
- Extruded Aluminum Construction
- Anodized Matte Finish
- Consult Factory for Custom Lengths & Finishes

#### Application



#### Dimensions

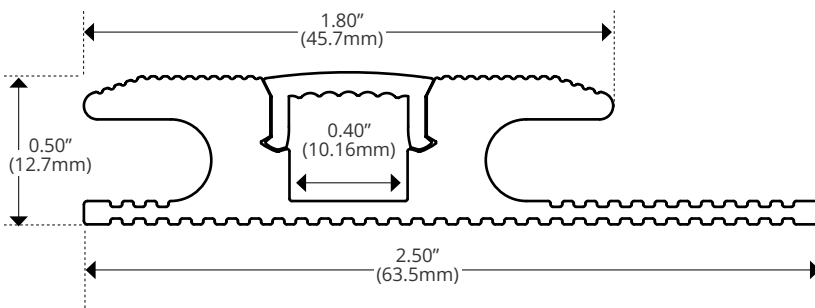

Kelvix reserves the right to update the product specifications at any time. To maintain warranty, field modifications must follow approved Kelvix installation instruction.

Fixture Type \_\_\_\_\_

Project Name \_\_\_\_\_

Location \_\_\_\_\_







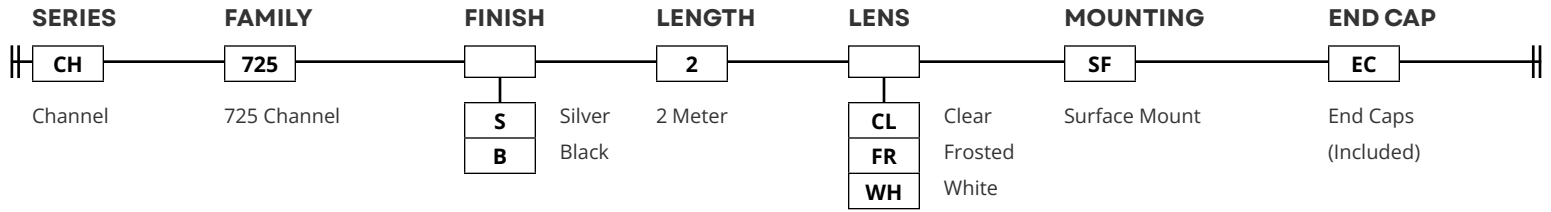

# Product Code Builder

## CH-725

### Product Code Builder

Example: CH-725-S-2-CL-SF-EC

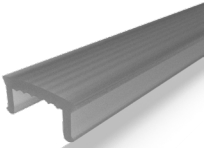

FINISH	LENS
<b>Silver</b> 	<b>Clear</b>  CH-LNS-725-CL-2M
<b>Black</b> 	<b>Frosted</b>  CH-LNS-725-FR-2M
	<b>White</b>  CH-LNS-725-WH-2M

TRANSMISSION	
CL	90%
FR	75%
WH	35%

END CAP
<b>Silver</b>  CH-EC-725-S
<b>Black</b>  CH-EC-725-BK

Kelvix reserves the right to update the product specifications at any time. To maintain warranty, field modifications must follow approved Kelvix installation instruction.

Fixture Type \_\_\_\_\_

Project Name \_\_\_\_\_

Location \_\_\_\_\_