



Installation Instructions

Signwave 3 PSF

Safety Precautions



PRODUCT MODIFICATIONS

Product modifications are not allowed, please reach out to Kelvix for any necessary modifications.

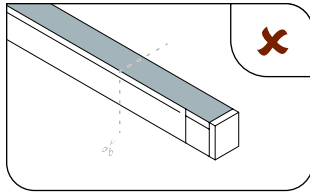

BENDING DIRECTION

Please note and follow the bending direction marked on the product, otherwise PCB damage and light failure may occur.

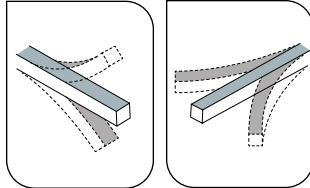

TWISTING

Do not twist or bend product excessively. Do not hit or pull the product with excessive force.

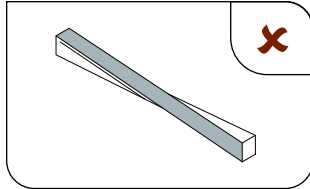

CABLE HANDLING

The first 2.36" (60mm) of the cable should maintain its natural state before any bending accrues.

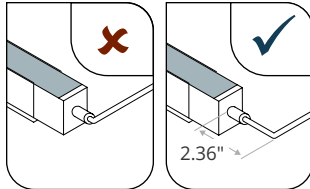

POWER TESTING

Do not power up while coiled for over 30mins. This may lead to overheating and damage.

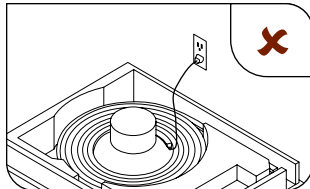

UL676 RATED J-BOX

Only wire fixtures with a UL676 rated waterproof cable junction box. Do not use other methods to wire fixtures.

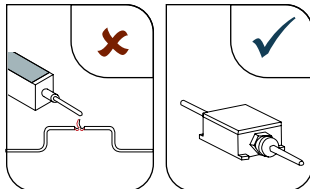

BENDING LIMITS

Do not bend product smaller than bending diameter. 11.81" (300mm)

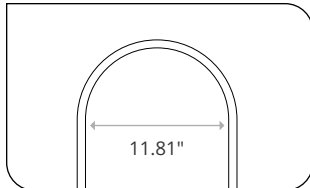

NEC 680

When installing in or near a pool, spa, or fountain, a Signwave UL 676 product must be used and must be installed in accordance with NEC 680 guidelines.

UL 676

UL 676 Underwater Luminaires / CAN/CSA C22.2 No. 89-1976 / UL 8750. This certification conforms to Articles 680 and 682 of the National Electrical Code® for installation in swimming pools, fountains, spas, and natural or artificially made bodies of water. File# E532381

CHEMICAL LIMITS

Ensure all installation conforms to UL676 and NEC 680 Standards
Only use Plastic Mounting Channel (SW-K-CH-PL-2M or SW-K-CLP-PL) for PSF installations
Ensure pool/spa temperature does not exceed 45°C
Ensure sanitation chemicals meets but does not exceed following limits:

Free Chlorine	≤2PPM
Ozone	≤0.3PPM
Salt	≤4%

Fixture damage due to chemical environment will not be covered under warranty.

Proper Chemical Handling:

- Always Pre Dissolve. Mix disinfectants in a separate container of water first, and ensure full dissolution before adding to the water.
- Pour the mixture at least 3 feet away from the installed LED Fixture.



Installation Instructions

Signwave 3 PSF

FLEXIBLE
NEON

Additional Precautions

For best performance and lifespan, do not load the power supply more than 80% of its labeled wattage rating.

This electronic product is sensitive to mishandling and may incur damage. Any improper soldering or modifications could lead to the voiding of the warranty. Kelvix reserves the right to assess warranty cases based on various factors.

Avoid puncturing or penetrating the product with foreign objects, as this could lead to a short circuit.

Ensure that the ambient temperature does not exceed 50°C/122°F during installation to guarantee the designated rated lifetime. Fixture temperature should fall between 63°F - 93°F (17°C - 34°C) during installation.

Unpacking

Incorrect unpacking may cause PCB fracture or damage to electronic components and lead to light failure. Do not unfurl Signwave from the middle of packaging.

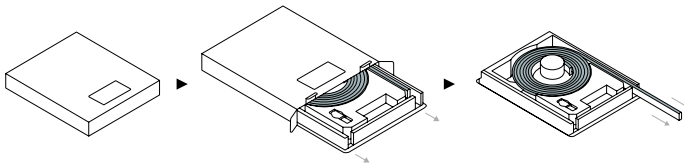

Uninstalling

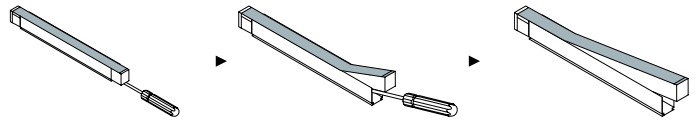

Prepare screwdriver at the base between the channel or clip and the product.

Move the handle of the screwdriver upward until one end of the product is out of the channel or clip.

Hold both sides of the product by hand and slowly pull the product out of the channel or clip until completely released (max angle 15°).



At minimum, two people should be used to install product into channel. One person should be installing product into channel, while another person is carrying product to ensure Signwave does not exceed maximum bending angle.



Installation Instructions

Signwave 3 PSF

Installation Positions

Determine the best method for installation. Ensure that the max depth does not exceed 16 feet, including the depth of the channel.

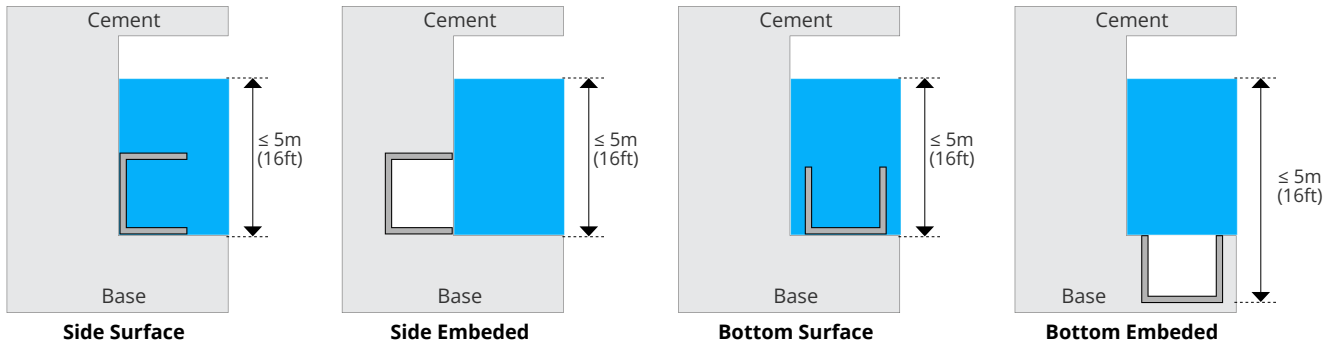

Base surface should be hard and flat, such as cement, brick masonry, marble, etc.

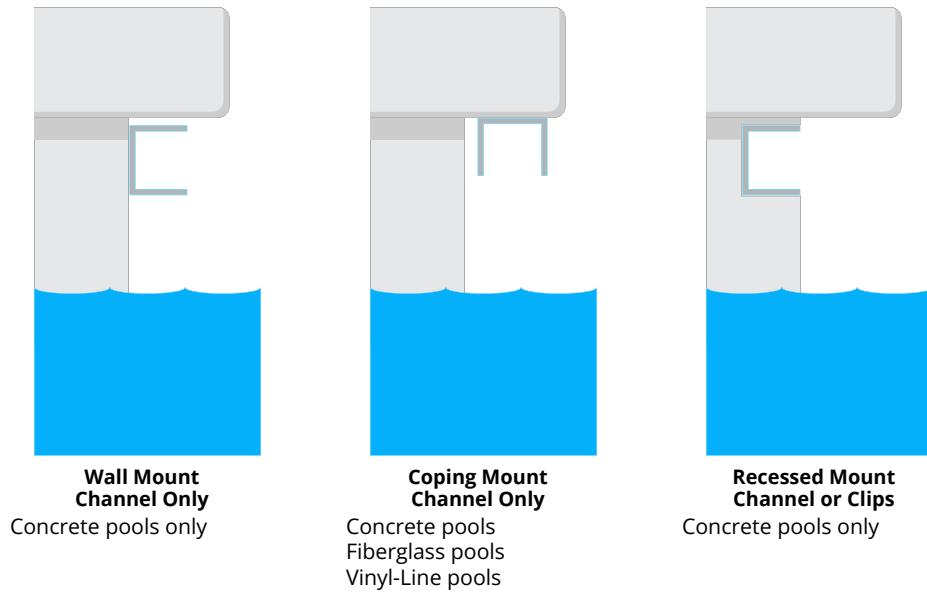

Slotting

The width and depth of the installation location should be ~2mm larger than the dimension of the channel or clips.

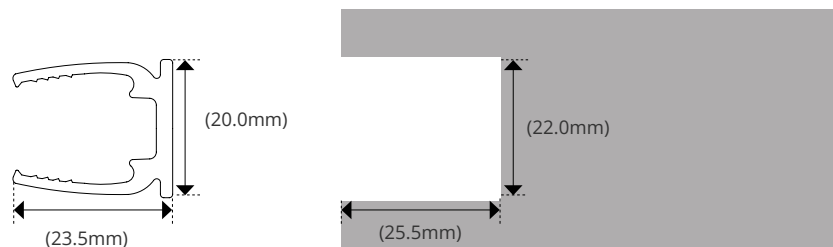



Installation Instructions

Signwave 3 PSF

Cable Conduit

Ensure only one cable is used per conduit.

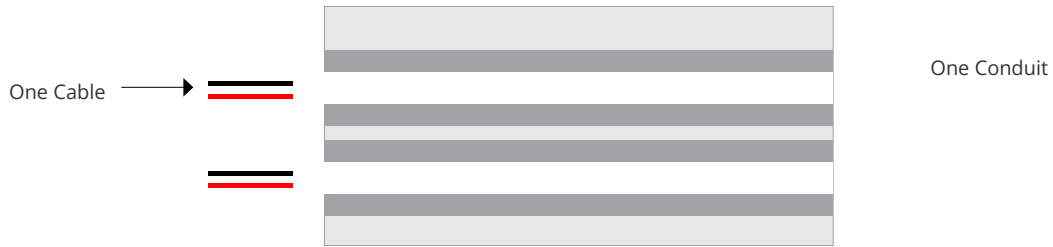

After installing fixtures, seal the inlet and outlet hole with silicone or resin to avoid water ingress into the cable conduit. Ensure the waterproof connectors are away from the water and conform to national and local codes.

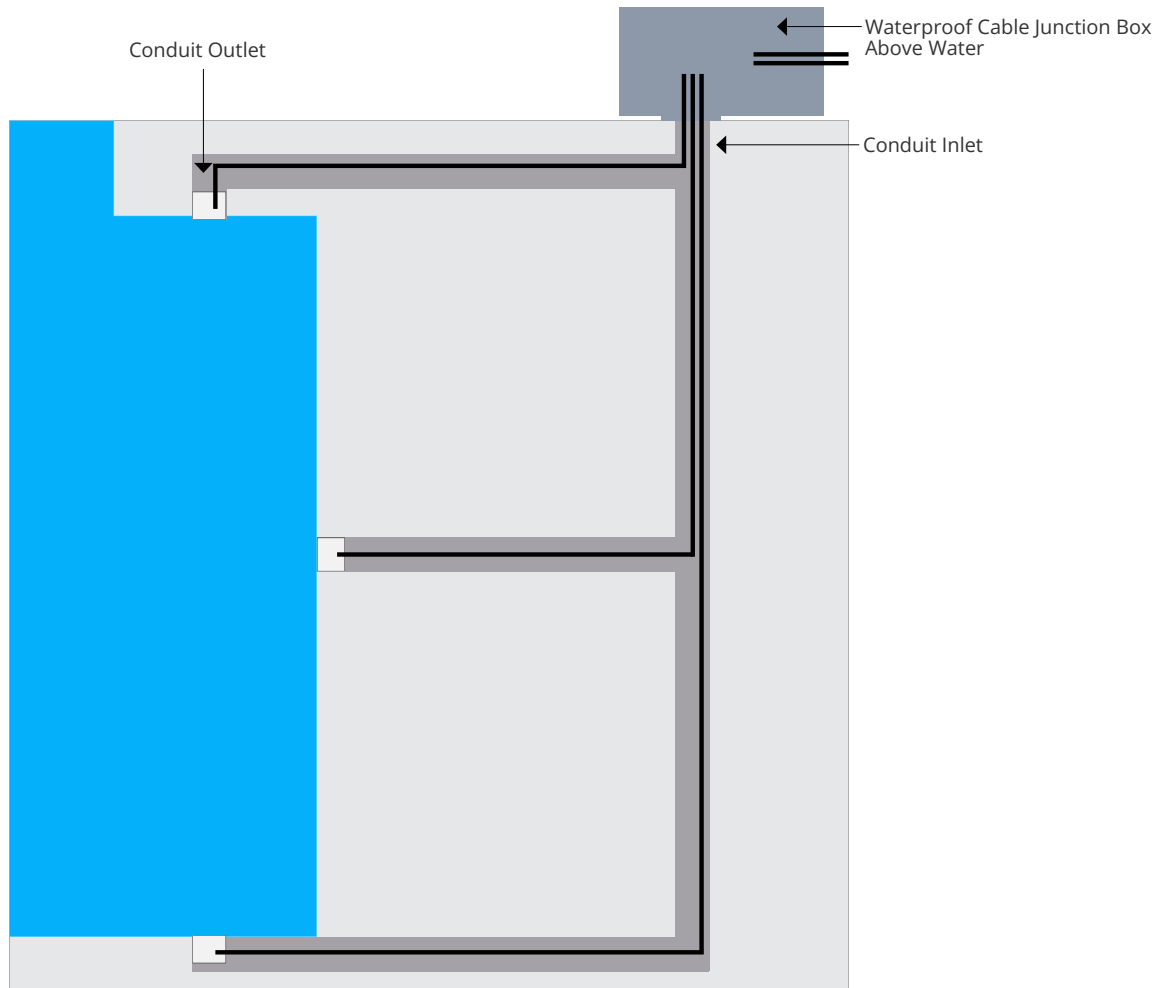

Kelvix reserves the right to update the product specifications at any time. Field modifications will void UL listing and warranty.

Fixture Type _____

Project Name _____

Location _____



Channel Installation Guide

Signwave 3 PSF

1 Measure and cut channel to length as needed.

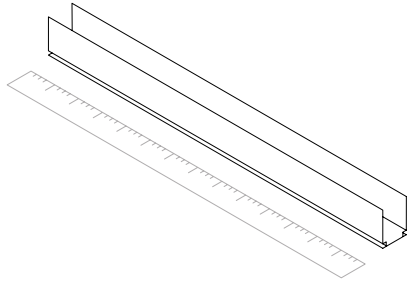

PROFILE LENGTH

Reserve 0.39"-0.78" (10-20mm) distance between the connector and channel.

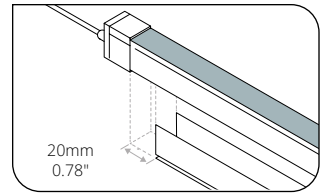

PROFILE CUTTING

Make sure the cross section of the channel is smooth without any burrs.

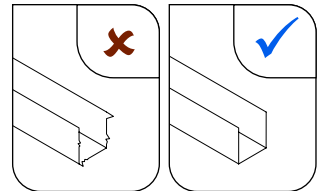

2 Screw channel through pre-drilled holes directly into mounting surface.

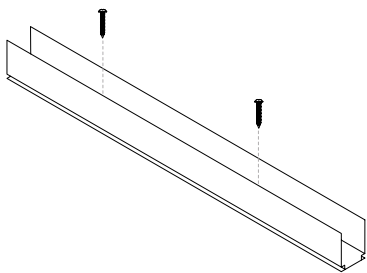

PROFILE ALIGNMENT

When using multiple channels the channel junctions should be aligned and the gap between should be at least 0.19" (5mm).

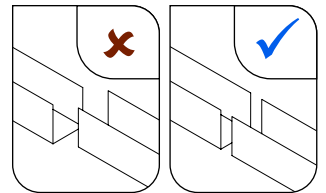

EXPANSION JOINTS

Do not connect two channels at an expansion joint. Cross the expansion joint near the middle of the channel. Channel should be screwed down on both sides of expansion joint/seam.

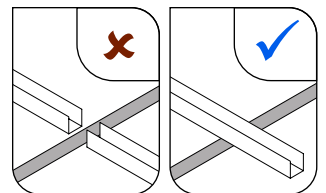

PROFILE SECURING

Ensure screws are driven vertically and flush to bottom edge to avoid damaging the outer jacket during installation.

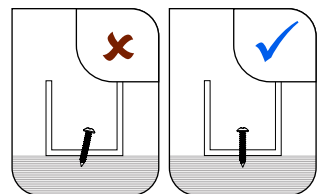



Channel Installation Guide

Signwave 3 PSF

3

Starting at one end, place product in channel and press down along entire length with your palm.

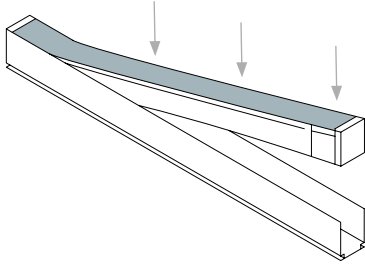

POWER FEED

Ensure that product is correctly oriented with power feed end toward power source.

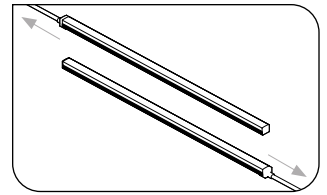

BENDING

Do not exceed 15° over 6" angle when installing the product into the channel.

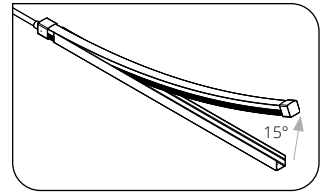

TWO-PEOPLE REQUIRED

At minimum, two people should be used to install product into channel. One person should be installing product into channel, while another person is carrying product to ensure Endurawave does not exceed maximum bending angle.

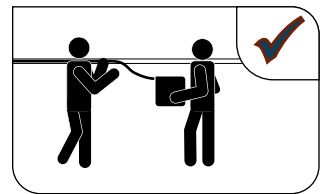
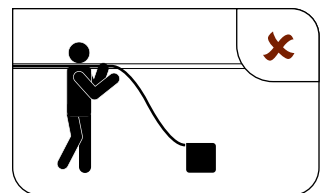



Clips Installation Guide

Signwave 3 PSF

- 1** Determine clip layout and mark clip location on mounting surface. Place a mounting clip minimum every 12 inches. Ensure that Signwave does not exceed maximum bend angle.

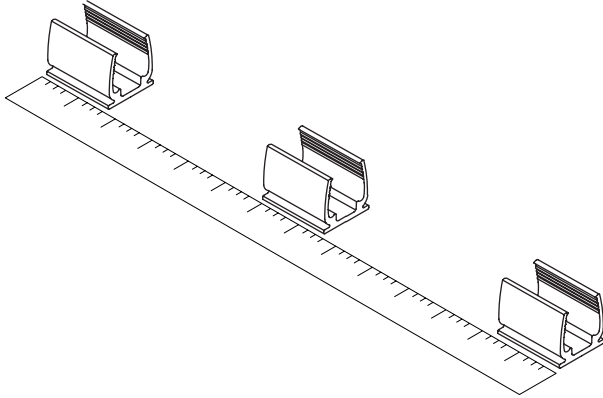

PROFILE LENGTH

Reserve 0.39"-0.78" (10-20mm) distance between the connector and channel.

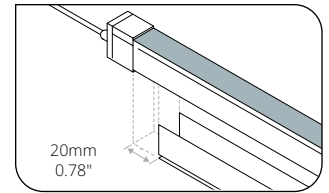

- 2** Screw channel through pre-drilled holes directly into mounting surface.

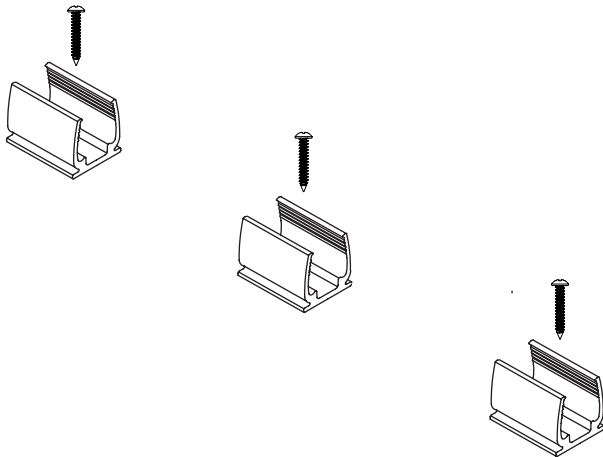

PROFILE SECURING

Ensure screws are driven vertically and flush to bottom edge to avoid damaging the outer jacket during installation.

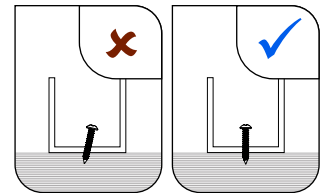



Clips Installation Guide

Signwave 3 PSF

3

Starting at one end, place product in channel and press down along entire length with your palm.

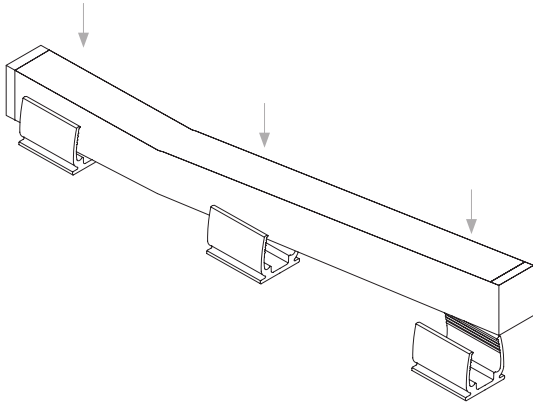

POWER FEED

Ensure that product is correctly oriented with power feed end toward power source.

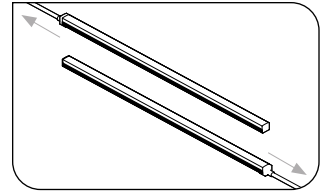

BENDING

Do not exceed 15° angle when installing the product into the channel.

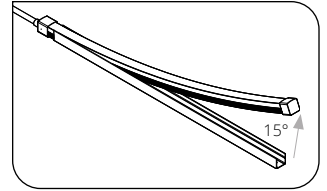

TWO-PEOPLE REQUIRED

At minimum, two people should be used to install product into channel. One person should be installing product into channel, while another person is carrying product to ensure Endurawave does not exceed maximum bending angle.

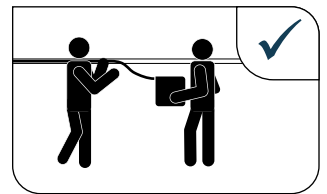
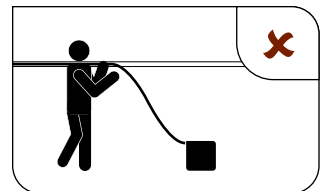

Bend Direction Specific Instructions

