

Connect _____
Relax. Color!

Illuminate your world with creativity and calm during this busy season. Instill relaxation, one dot at a time.



Connecting
the Dots
to Brilliant
Lighting



Innovative *LED Lighting Services*

THE KELVIX WAY

Behind every Kelvix project is an entire team of specification professionals. Our Applications Engineers, Product Engineers, and Project Managers are at your disposal before you even place a single order. We're standing by to make your job easier through our innovative LED lighting services. Get in touch to experience The Kelvix Way.

Easy As...

1

2

3

1

PROJECT MANAGEMENT

Our project management professionals coordinate complex projects and ensure smooth execution from start to finish. We're adept at seamlessly navigating any order or design changes that may arise, guaranteeing concierge-level support at every step. Whatever your needs, we'll manage timelines and budgets, offer expert insight, and handle order forensics (assessing product capabilities, rooting out discrepancies, etc.).

- + Managing Project Timelines
- + Expert Insight & Support
- + Managing Budgets
- + Order Forensics

2

DESIGN & SPECIFICATION ASSISTANCE

Our team of LED lighting experts can help bring your vision to life through concept development and design assistance, in a consultation. We'll provide concept and design advice, suggestions, and more, documenting our ideas through drawings and takeoffs before you order.

- + Wiring Details
- + Detailed Takeoffs
- + Install Details & Elevations
- + Product Details & Shop Drawings
- + Power Layout & Mapping
- + Lighting Calculations

3

APPLICATIONS ENGINEERING & DESIGN SERVICES

Our advanced 3D rendering capabilities can turn design concepts into vivid visual representations of our products in action. Our skilled engineers excel in controls and programming, handling complex projects from upscale homes to large entertainment venues. Our precise lighting calculations ensure accurate project outcomes, and with on-site commissioning, we stand by our commitment to deliver results that exceed client expectations.

- + DMX Controls
- + Custom Programming
- + System Troubleshooting
- + Video Demos
- + Factory Pre-configuration
- + On-site Commissioning
- + System Training
- + Programming Samples
- + Rendered Demos
- + Color Matching & Verification

4

SAMPLES, MOCKUPS, & DEMOS

We offer numerous resources to help you gain confidence in your decision. It's one thing to look at calculations and designs on paper, but another to see it yourself in real-time. Experience your LED lighting products firsthand through free quality samples and physical mockups. Our team can arrange on-site or virtual demos to help you witness the quality of your LED lighting. Additionally, we have numerous product performance videos available and can conceptualize the details further via accurate 3D renders and lighting calculations.

5

MANUFACTURING & SHIPPING

The Kelvix Way is an end-to-end solution for your LED lighting needs. When your designs are finalized, we can assemble the products in-house if required. Letting our professionals take the reins gives you more precise and reliable products. You can be confident that your shipment will arrive when you expect it. We take pride in our 99% on-time delivery rate with the industry's fastest shipping times.

*Answers can be found in
the back of the book.*

Let's
Have Fun

Crossword Puzzle

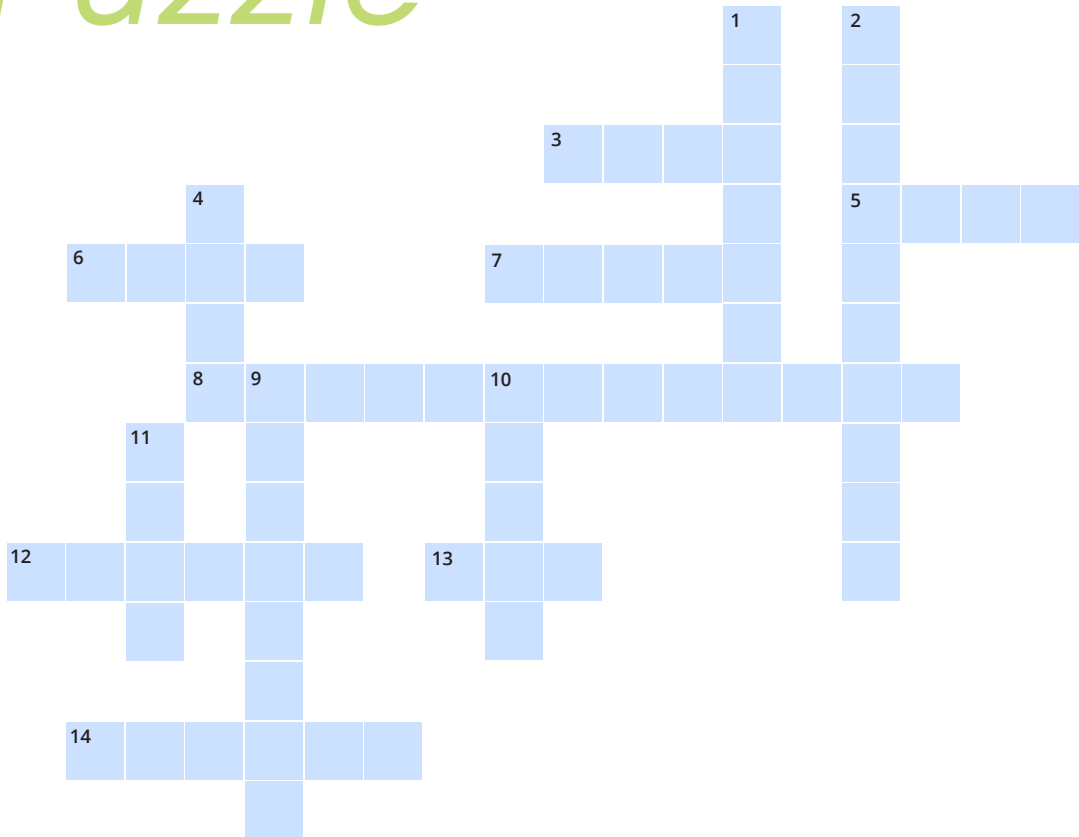

DOWN

1. General lighting that provides overall illumination.
2. An attribute of visual perception.
4. A measure of power consumption in a light source.
9. A light fixture set into a ceiling or wall.
11. Another term for a light bulb or a complete light fixture.

ACROSS

3. The glass enclosure that produces light when powered.
5. A soft, steady light without glare.
6. A directed path of light from a source.
7. Harsh, bright light that causes discomfort.
8. A system where lights are attached to a continuous track.
12. A switch that adjusts brightness levels.
13. A long-lasting, energy-efficient type of light.
14. Lighting used to highlight specific areas or objects.

Crossword Puzzle

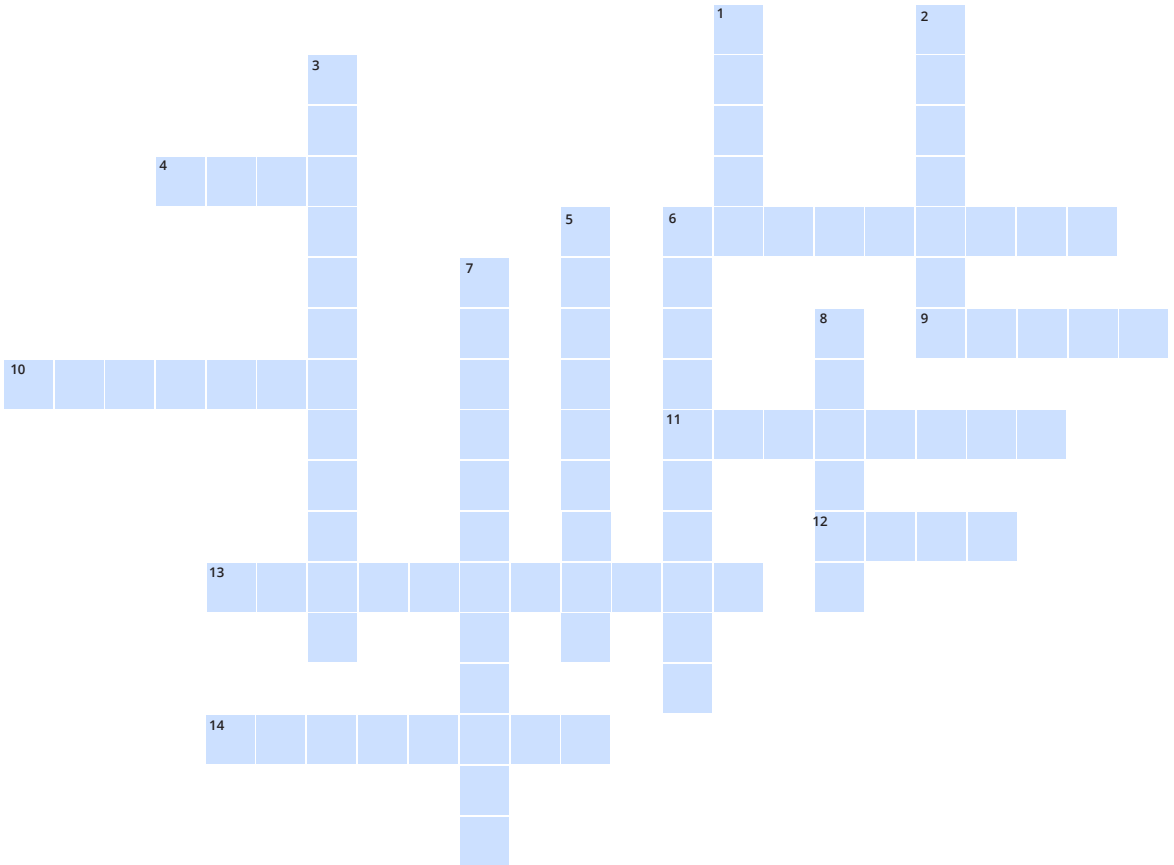

DOWN

1. LED, D.
2. Houses strip lighting.
3. Strip illumination.
5. An aluminum or plastic channel used to house and protect LED strips.
6. An attribute of visual perception.
7. A lighting feature that allows adjustment of color temperature.
8. The lens or reflector design that directs light output.

ACROSS

4. An alternative name for a light bulb.
6. The main spread of light emitted from a source, measured in degrees.
9. A measure of the total amount of visible light emitted from a source.
10. The process of sorting LEDs based on color and brightness consistency.
11. Dissipates excess energy efficiently.
12. An area of lighting usually built into ledges, recesses, or valences in ceilings.
13. Luminous intensity.
14. The term for using a combination of luminaires at different heights.

Lighting Word Search

V V H N K D I R E C T V I E W
Y Y T N Q A R K A P I I J K X
G C A R B N P M E Y P J S E V
C R A Y O N Q P U F A V I L E
R U B S U W F H Y D O U G V R
E N D U R A W A V E R N N I T
V D P Z T V Q R N O F I W X E
F V A W Y I T O V C L F A H X
I G O D P N O S U R O O V F Q
Z S S Z V E B I E O P R E L X
Z L E E X A F Q B S T M R E O
I I N A N Z T L G S I V Z X V
X N X Q F O R E X B X I Y F T
U X Q J I L V O K A Y P F I Q
F P J Y V O Q N A R I E A T B

WORDS TO LOOK FOR

ENDURAWAVE
FLEXFIT
UNIFORM
SLINX
OREX
PHAROS
DIRECT VIEW
CROSSBAR
VERTEX
ZOLO
FIZZIX

SIGNWAVE
ADVATEK
FLOPTIX
CRAYON
KELVIX
VINE





Let's Get
Creative

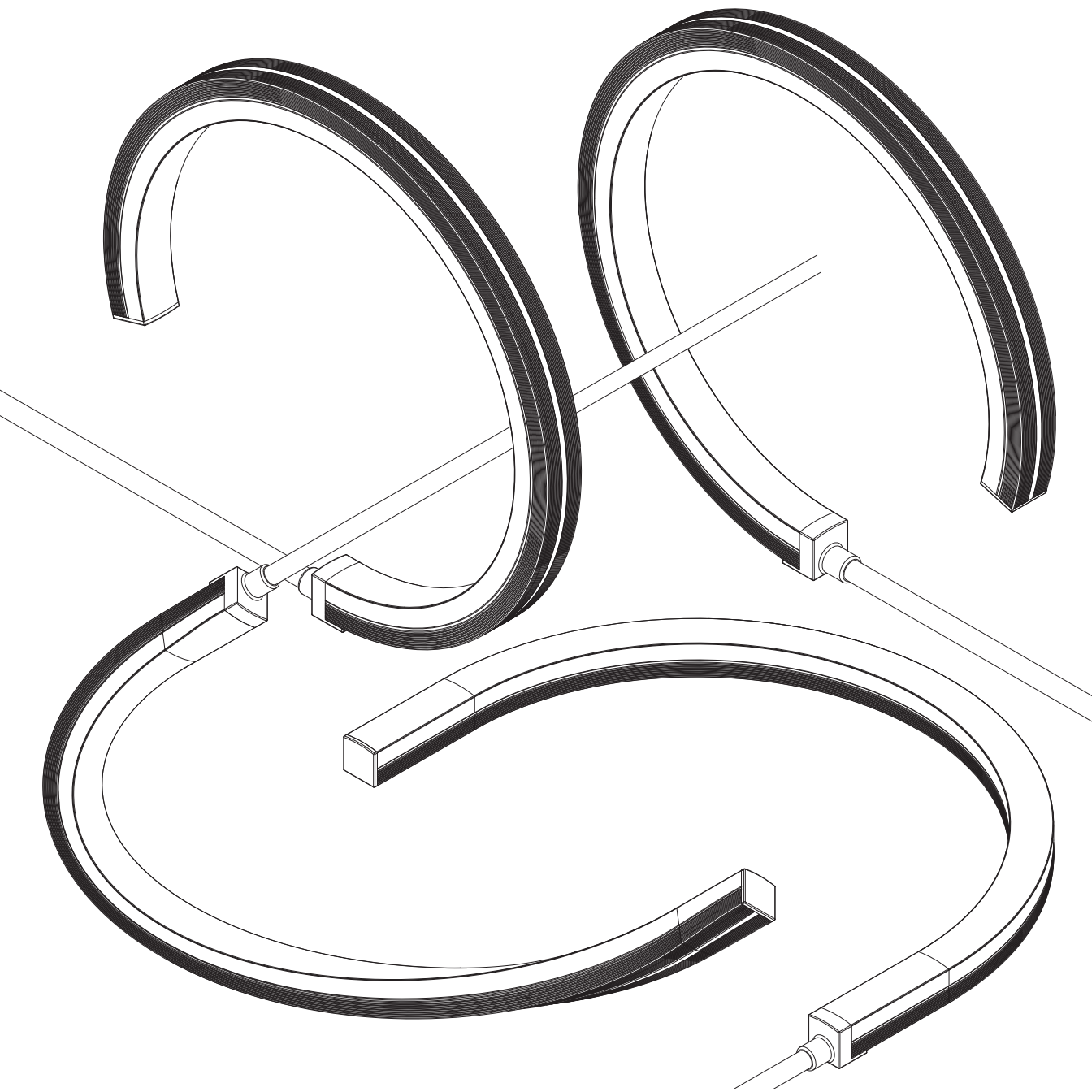

ENDURAWAVE

Endurawave is designed for dual bending in 3D applications, delivering best-in-class durability for all use cases, including outdoor environments. With high brightness, a wide viewing angle, and seamless fluid connections, this versatile series is available in white and RGBW, making it a top choice for dynamic lighting solutions.

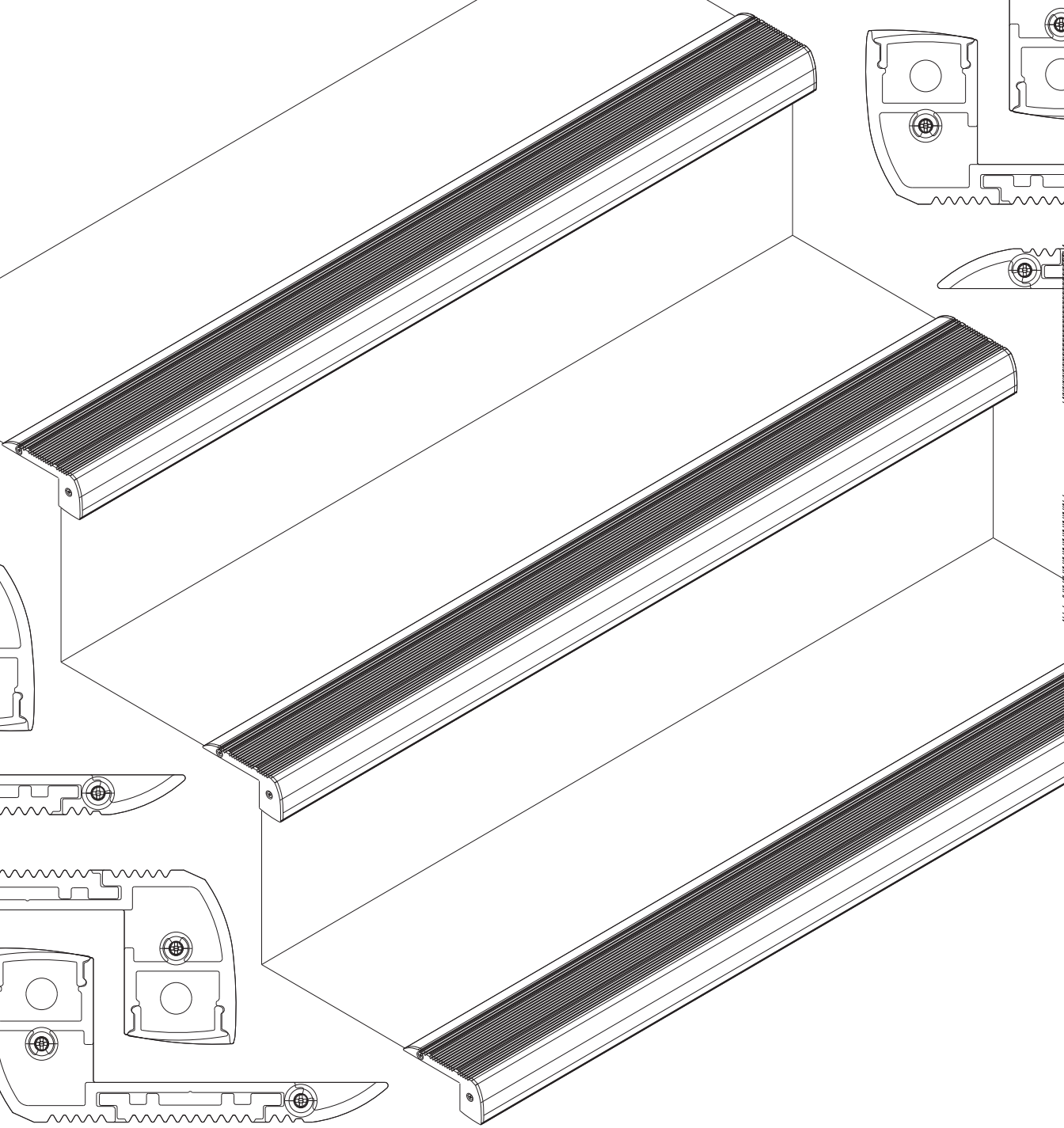

CH-224

A sleek stair mounting channel that fixes seamlessly to steps, providing illumination to allow for adequate visibility of stairs. A slim profile helps enhance safety.

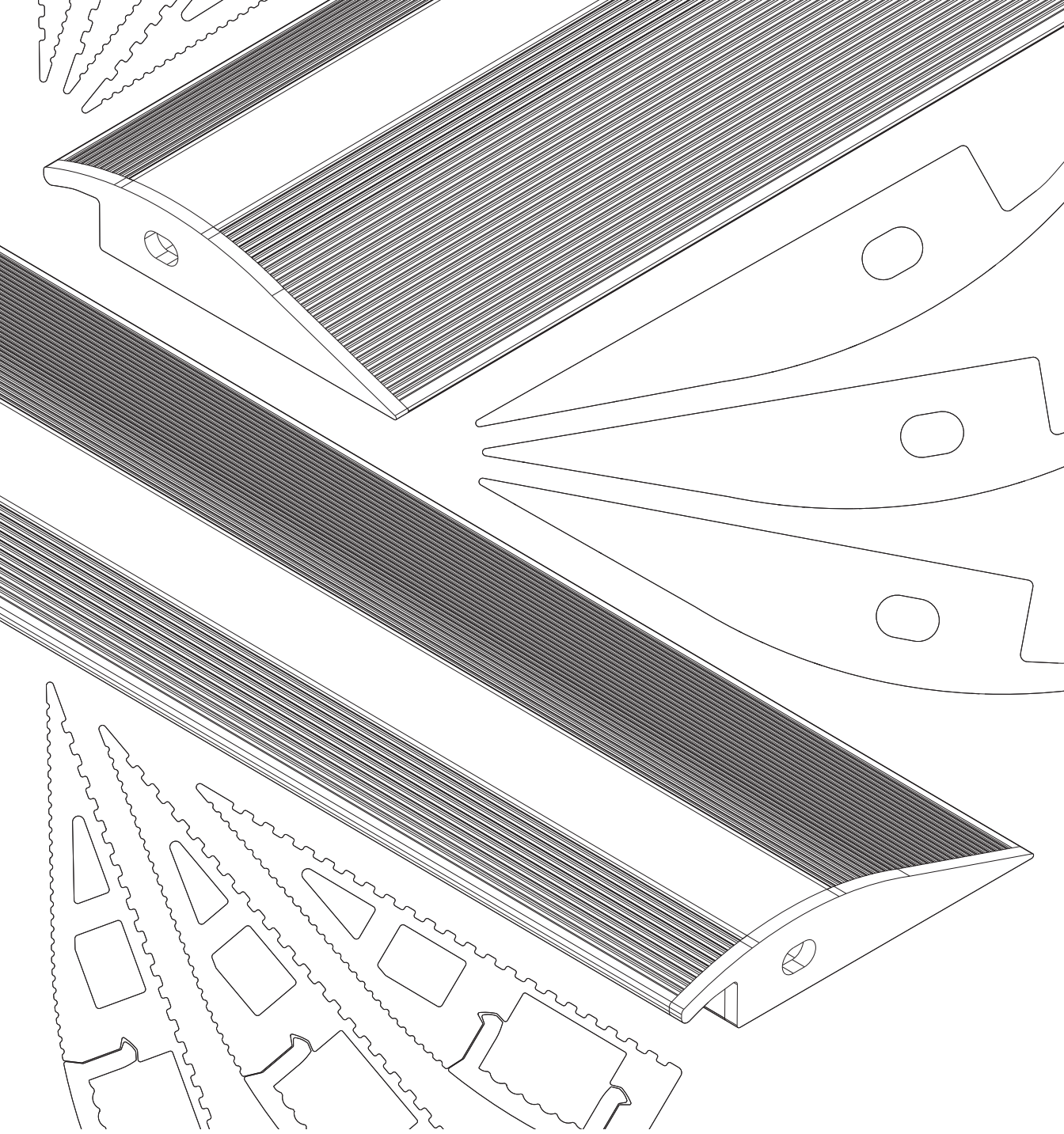

CH-724

A unique mounting channel with the capability to connect two different types of flooring together. Most commonly used as a transitional channel between carpet and hard surfaces. Ideal for lining aisle ways.

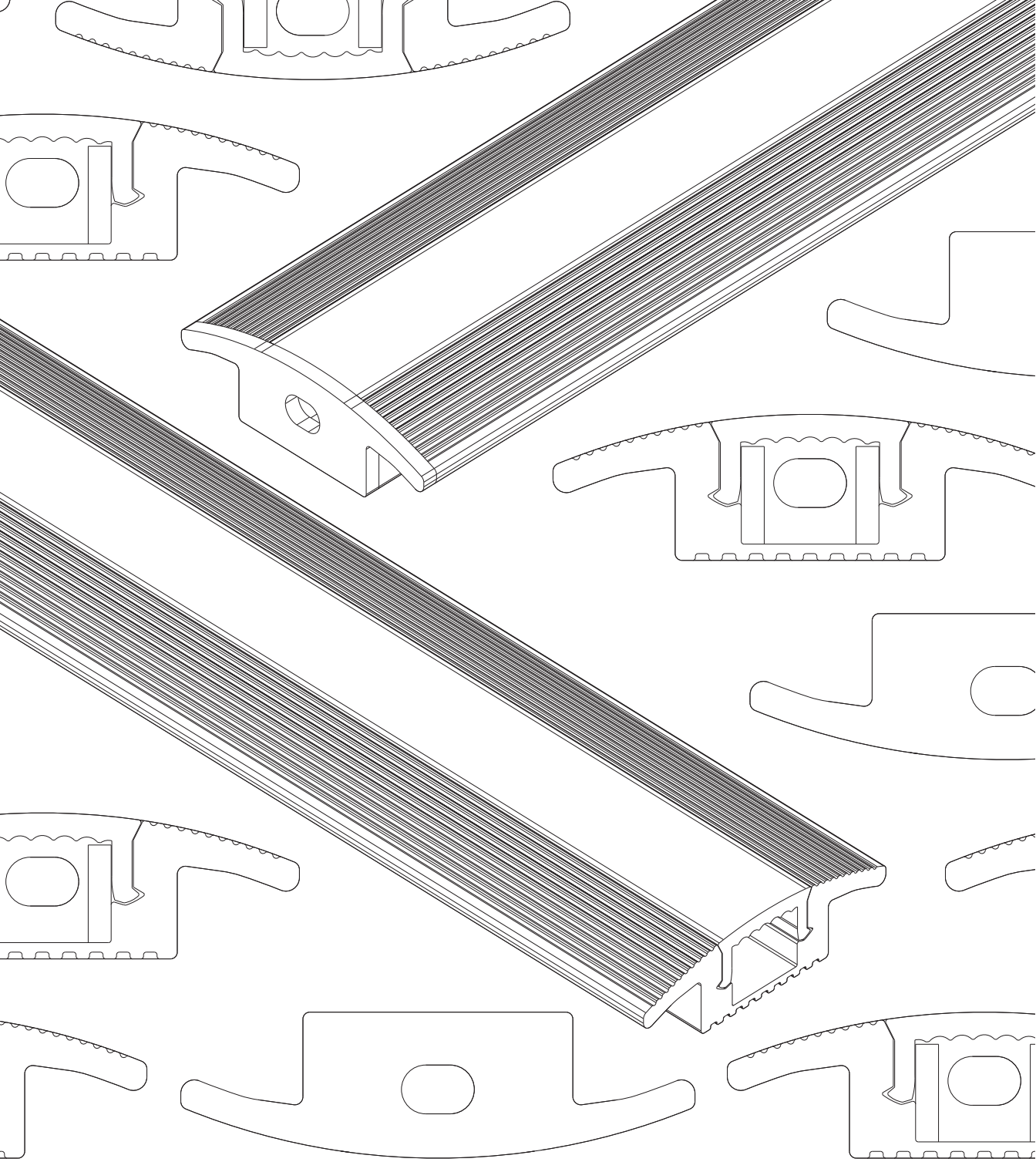

CH-723

A mounting channel that seamlessly connects carpet to carpet.
Often used to light walkways in theaters or concert halls.

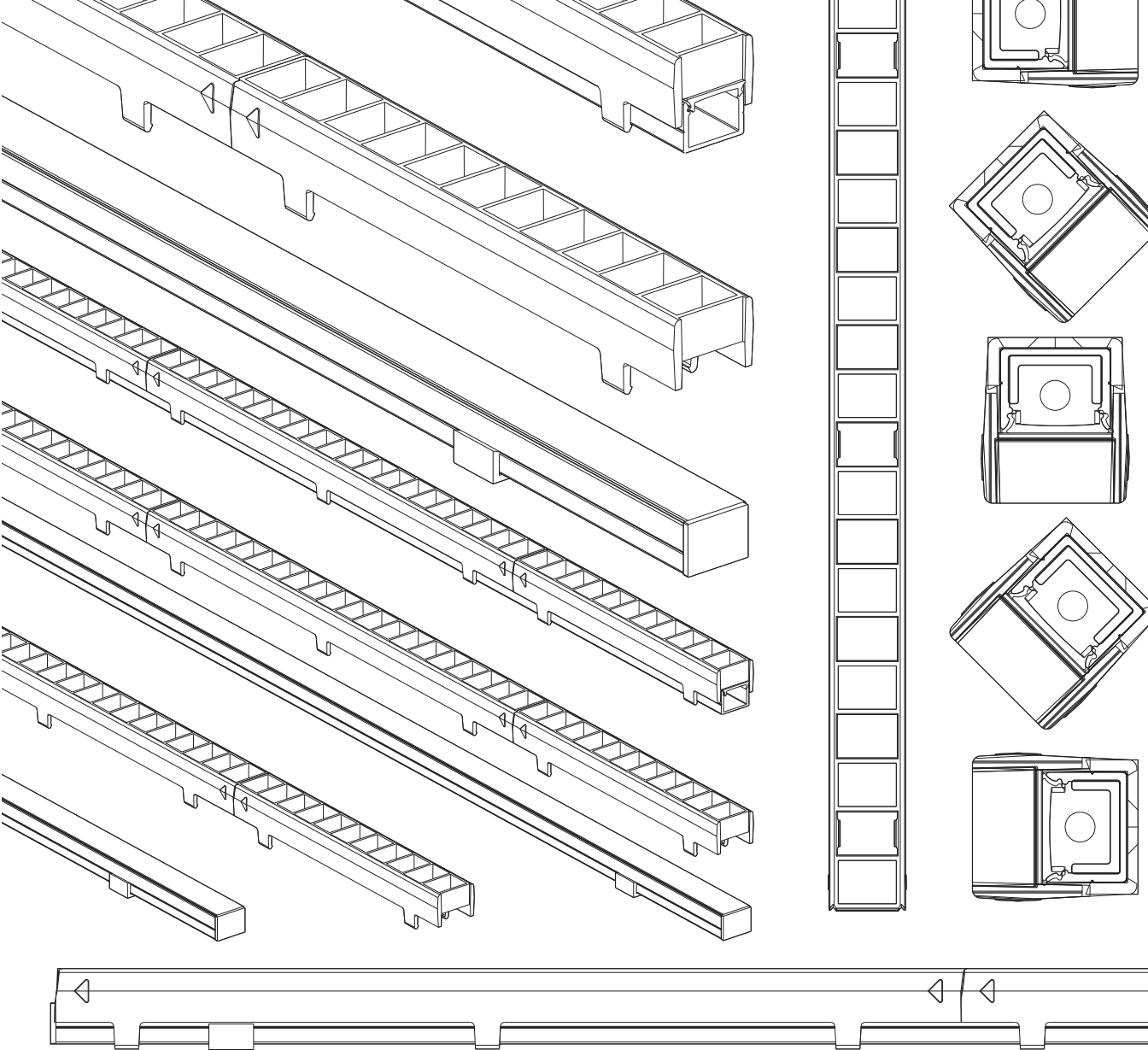

CH-409 LOUVER

The louver enables projects to use CH-409 in direct view applications while reducing glare even at high viewing angles. Typically, UGR sensitive applications like offices, museums, and residential spaces, aim for UGR values below 19, making our louver (UGR <13) an accessory that drastically lowers glare. While there is some light output reduction due to the louver, our wide offering of uniform tape lumen outputs gives customers the ability to configure the fixture to their specification.

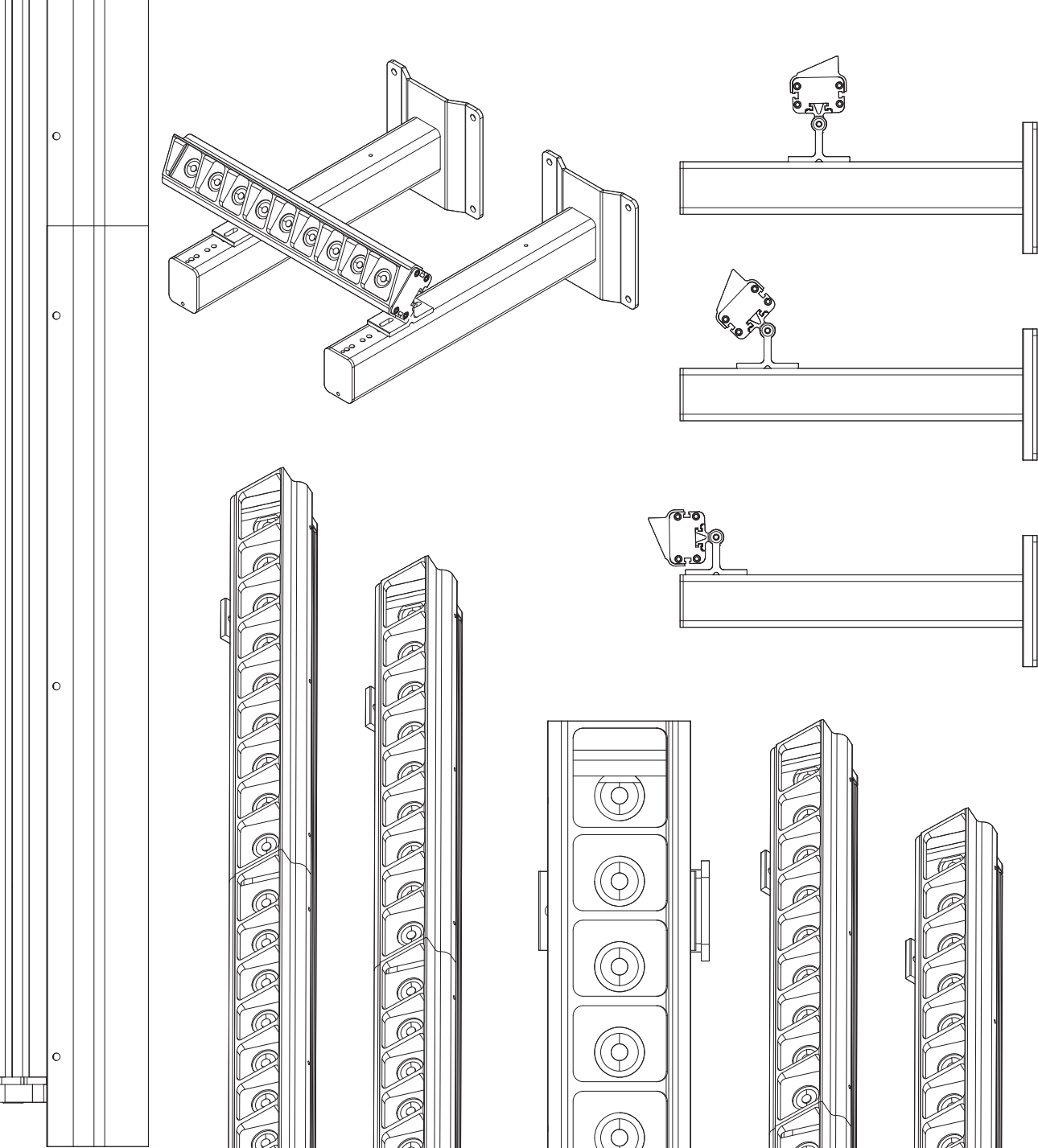

ZOLO 7

Zolo 7 is our brightest outdoor rated washer/grazer. While remaining slim, Zolo 7 offers 1100 lumens a foot! With multiple optics, kelvin temperatures, colors, and accessories Zolo 7 can light any project.

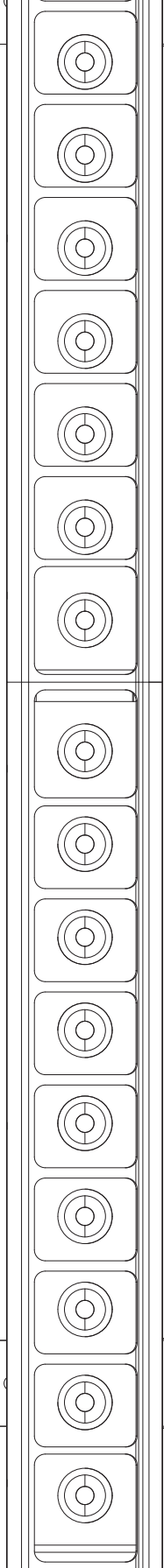
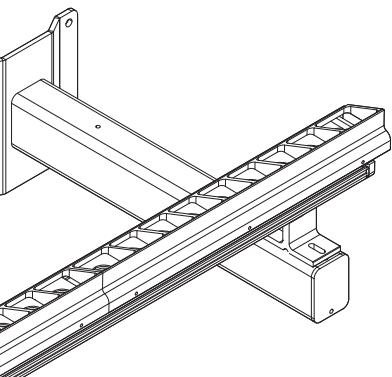
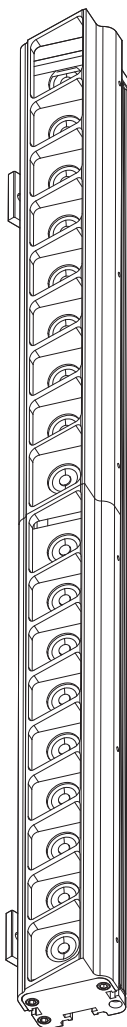
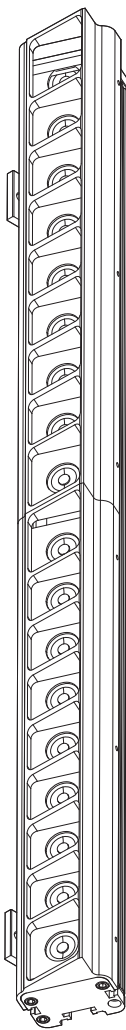
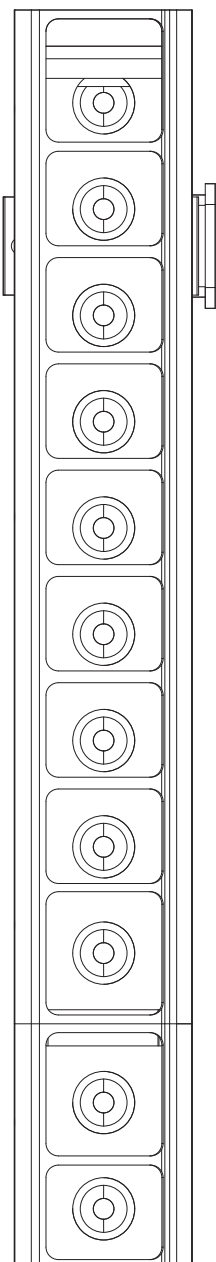
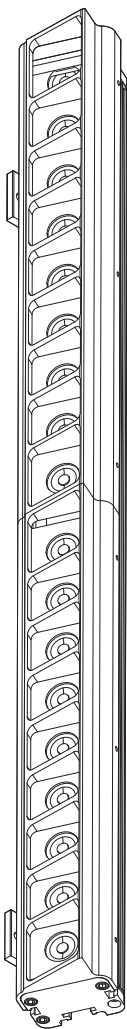
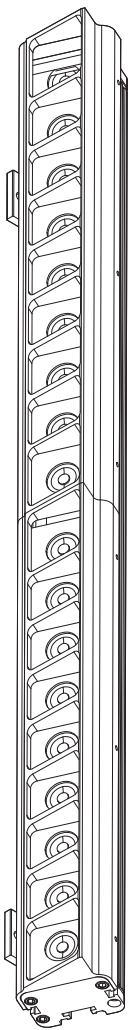
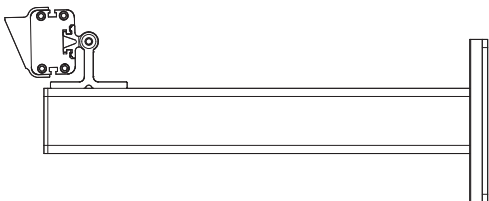
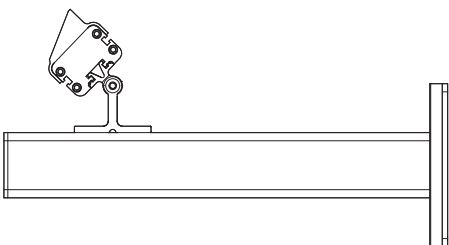
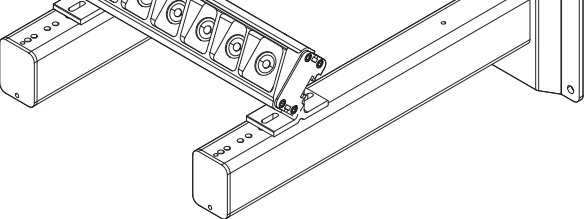

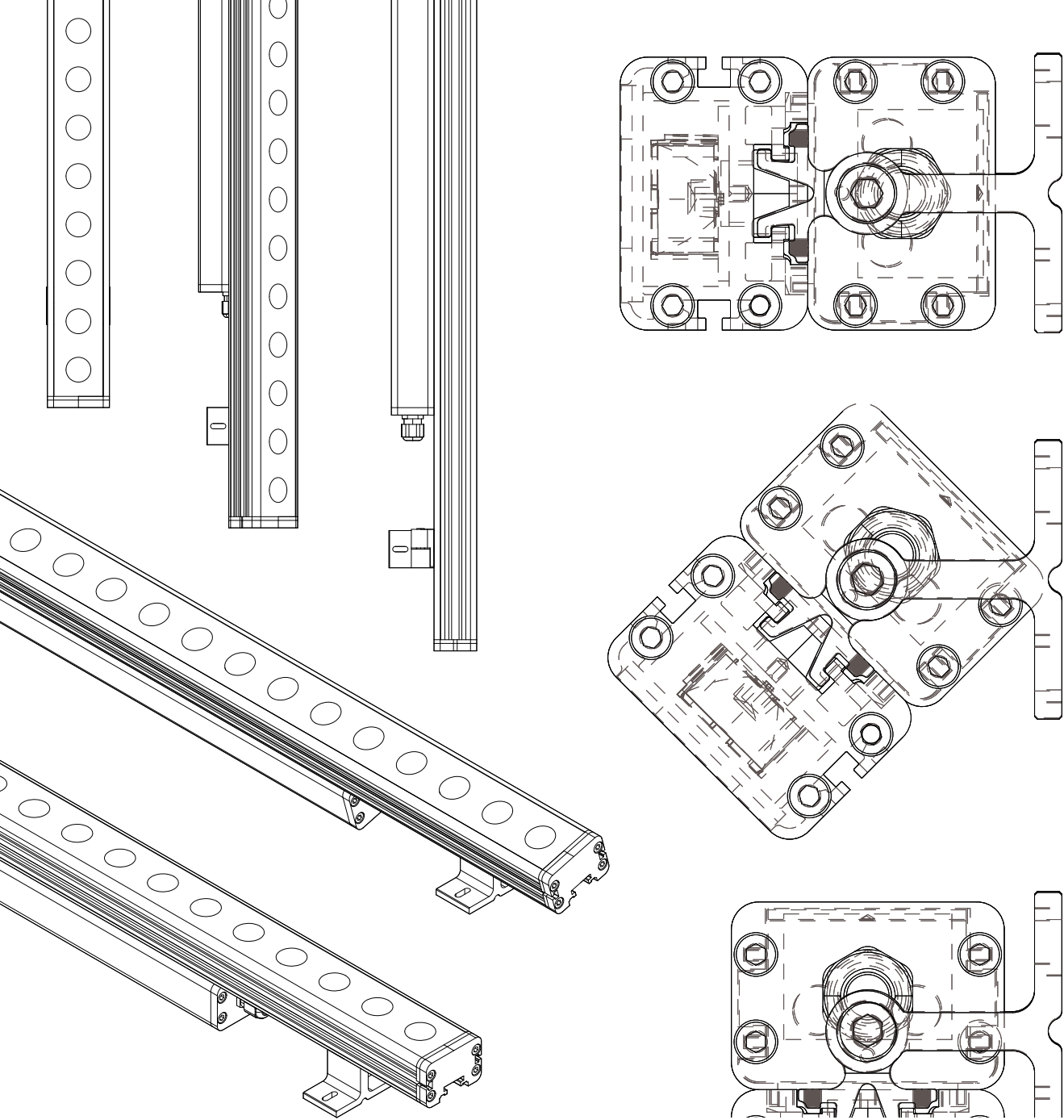

AC ZOLO 7

The AC Zolo 7 is the first line voltage option in our flagship grazing series. Available with a variety of optics, accessories, and color temperature options without the need for remote drivers. IP66 rated for Dry/Damp/Wet locations.

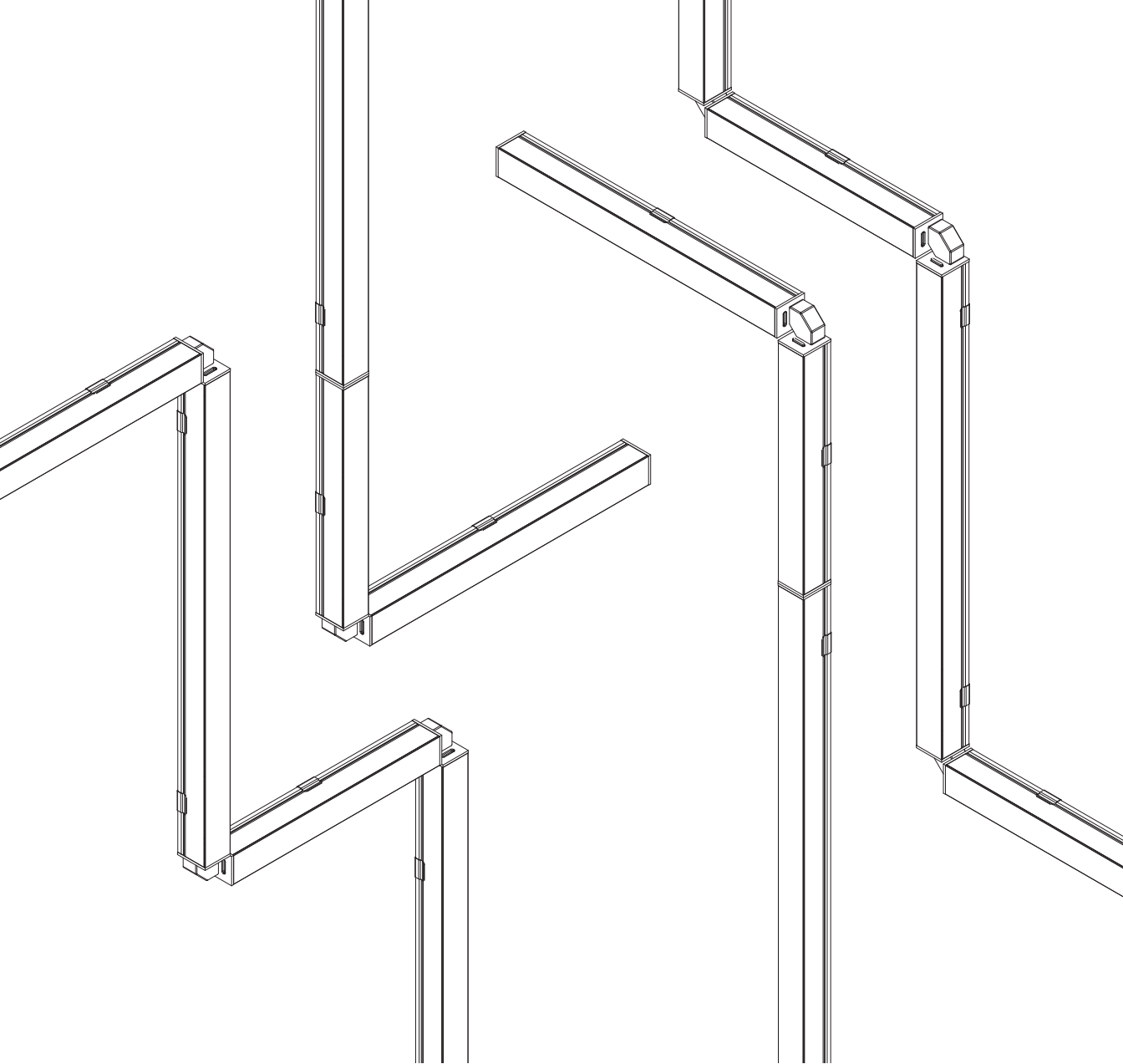

AC FIZZIX™

Fizzix™ offers pixel-free illumination combined with integral snap-together connectivity. A signature feature of Fizzix is the ability to change the lighting plane within the same run (DC version). In addition to creative shapes and direct-view lighting applications, Fizzix is fantastic for linear installations such as displays, coves, undercabinet, and toe-kick lighting. Available in the easy-to-install and maintain DC version (not pictured) and the AC (pictured above) version for use without a driver.





SCAN TO
LEARN MORE



43North

BUFFALO, NEW YORK

Products: Direct View 400 (Indoor), CH-0003





Creighton Hall

OMAHA, NEBRASKA

Products: Zolo 5, Zolo 7



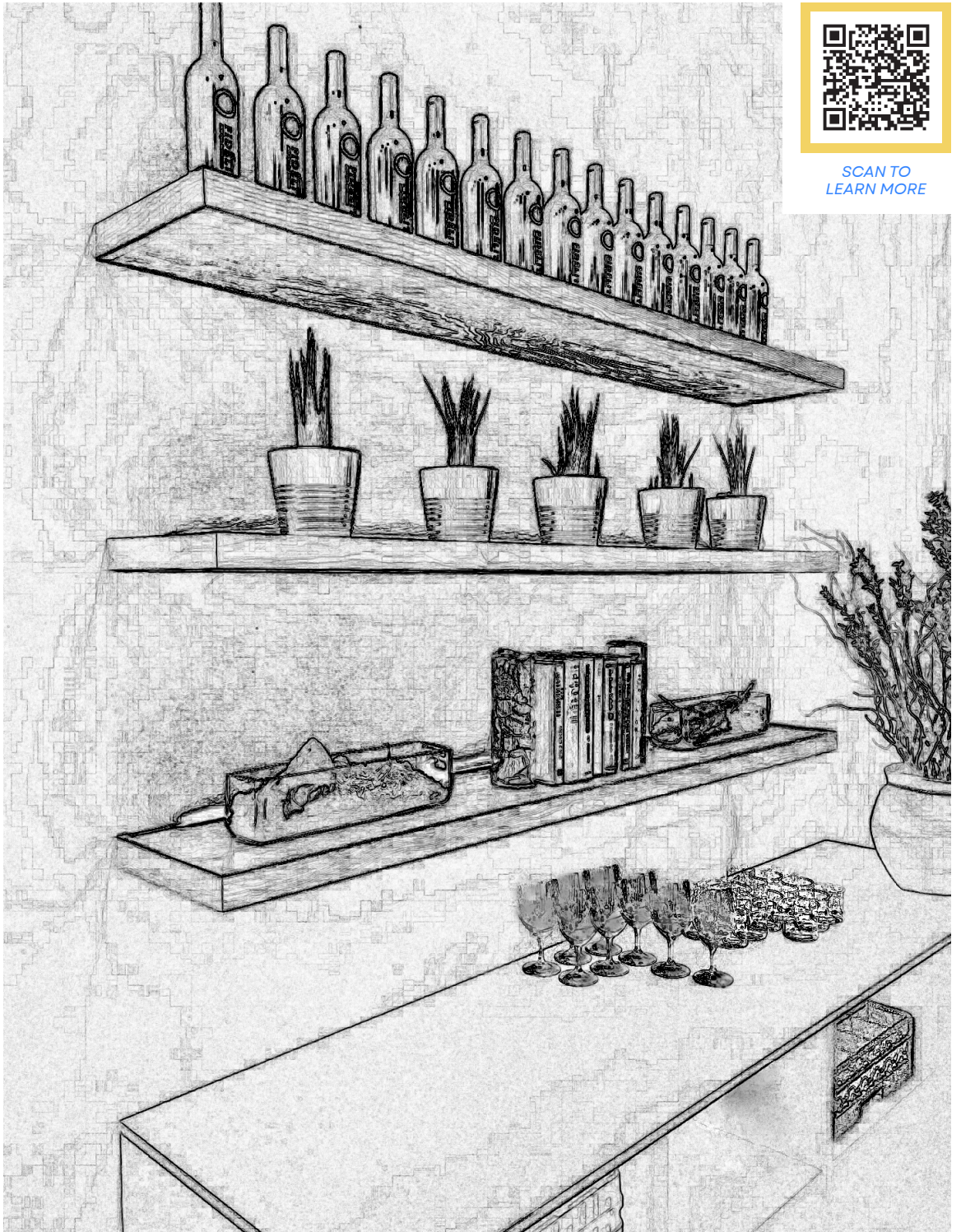

SCAN TO
LEARN MORE

Fidelitas Winery Tasting Room

WOODINVILLE, WASHINGTON

Products: Uniform Static White, CH-502-A, ULV36, Easy 502 Uniform Static White





SCAN TO
LEARN MORE



Bowen River Oaks

HOUSTON, TEXAS

Products: Signwave 3 RGBW

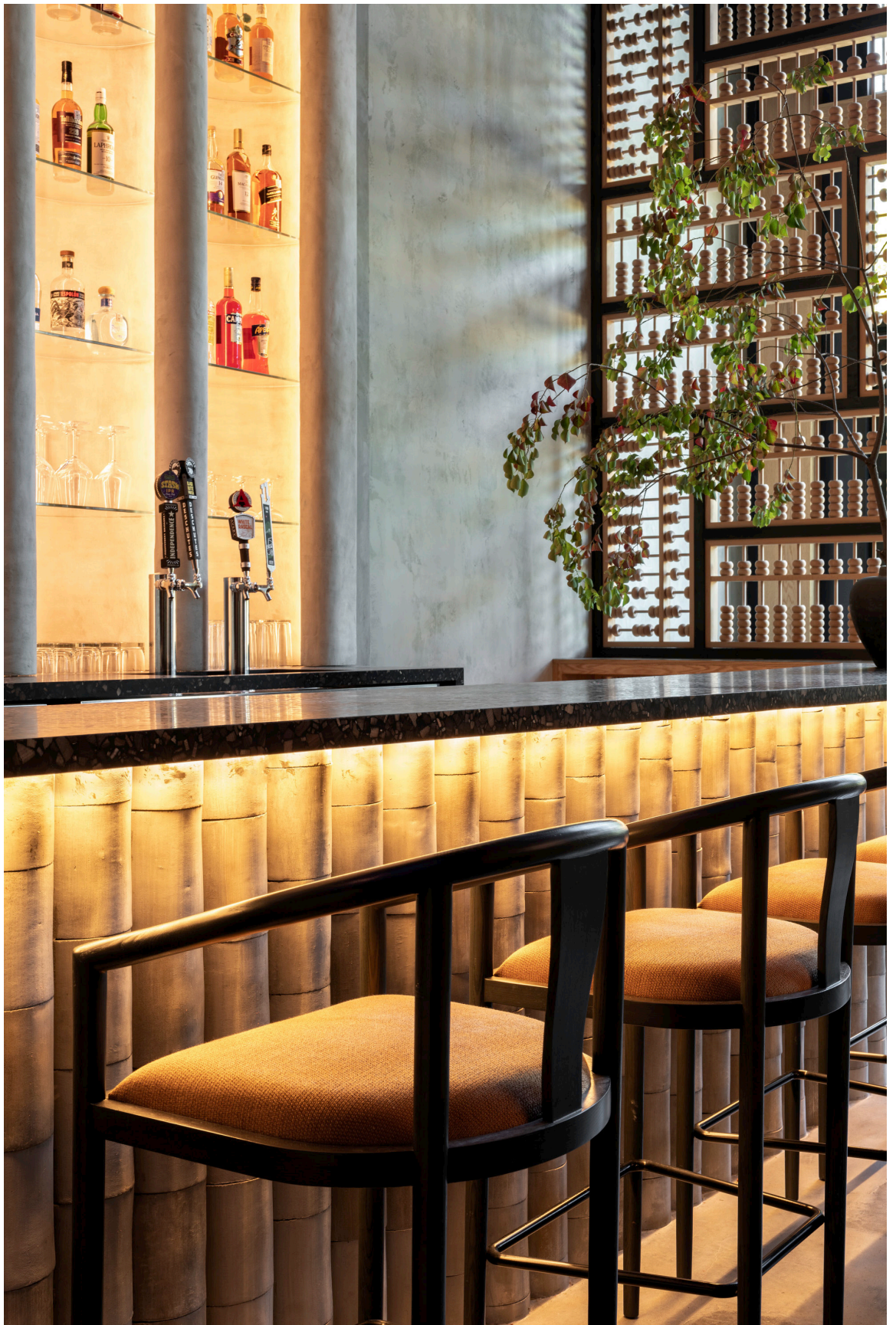

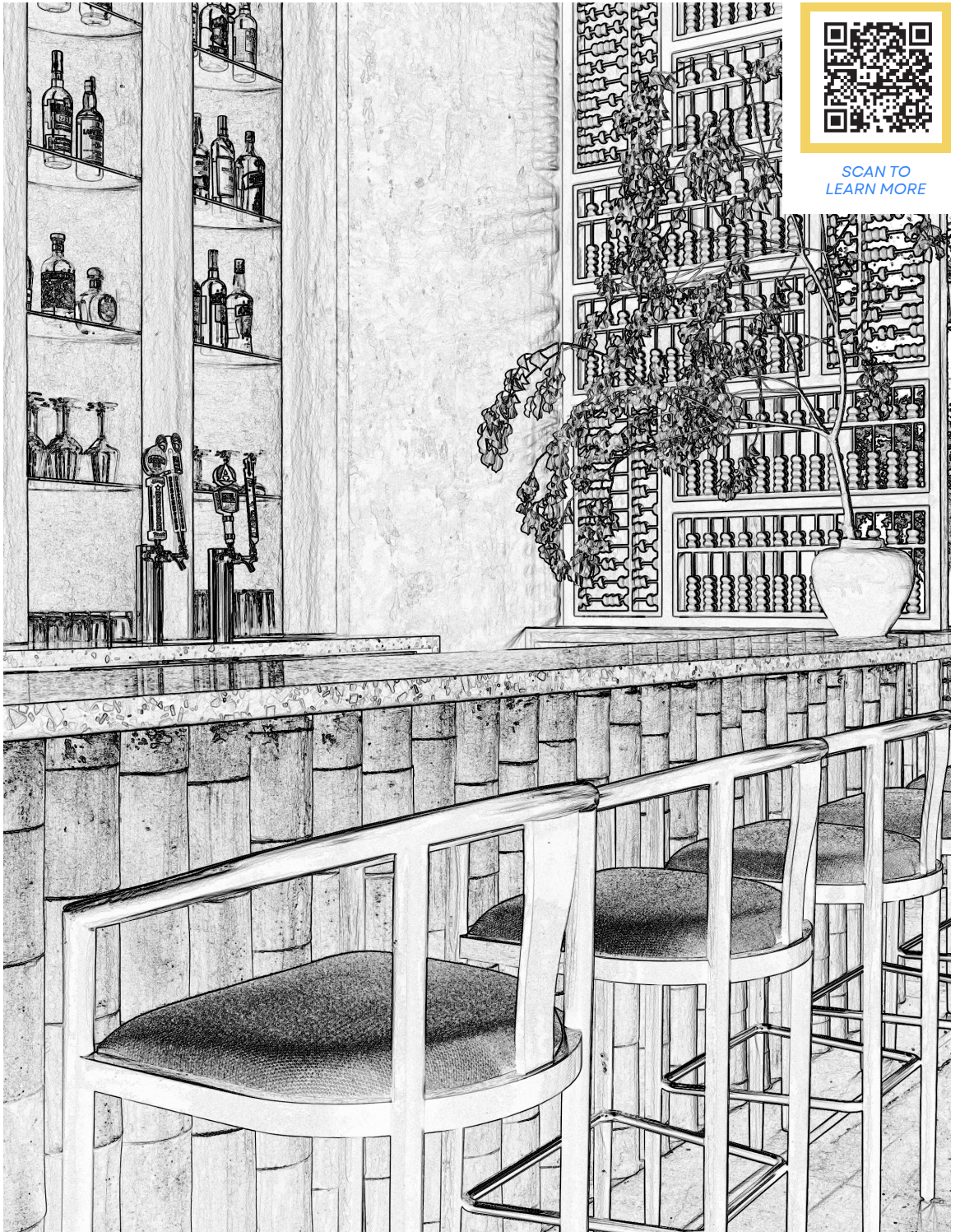

SCAN TO
LEARN MORE

Mala Sichuan Bistro

HOUSTON, TEXAS

Products: Direct View 200 (Indoor), Direct View 200 (Outdoor), CH-006, CH-014-C,
CH-602, CH-222, ULV36, ULV96

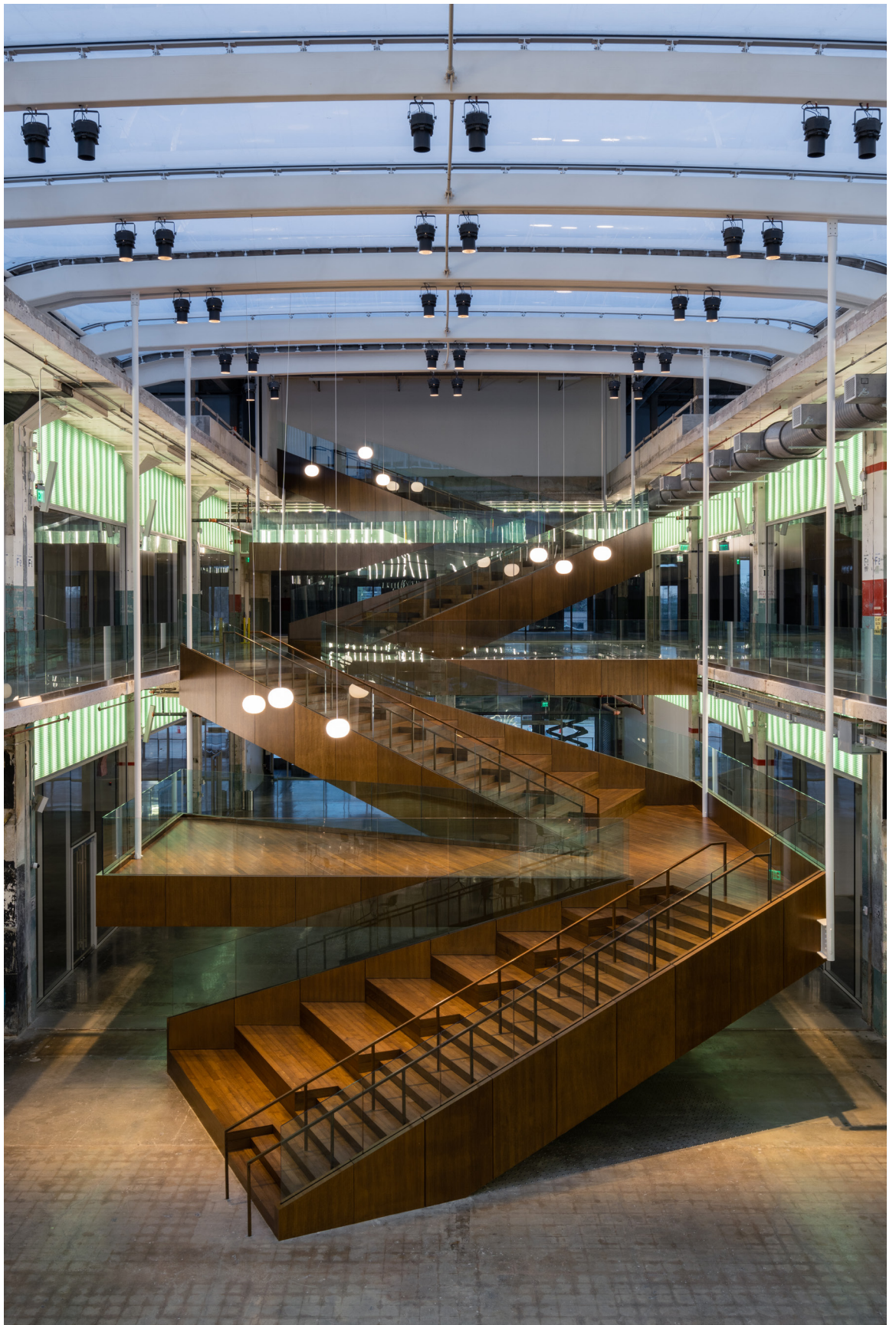



SCAN TO
LEARN MORE

Post HTX

HOUSTON, TEXAS

Products: Performance 300 (Indoor), Brian 630, Vertex 1000 (Indoor), CH-008,
Performance 800 (Indoor), CH-202, Direct View 200 (Indoor), CH-502-A



Let's Dare
to Dream



KELVIX®

KELVIX®





KELVIX®

KELVIX®





KELVIX®



Puzzle Answers

Crossword Puzzle

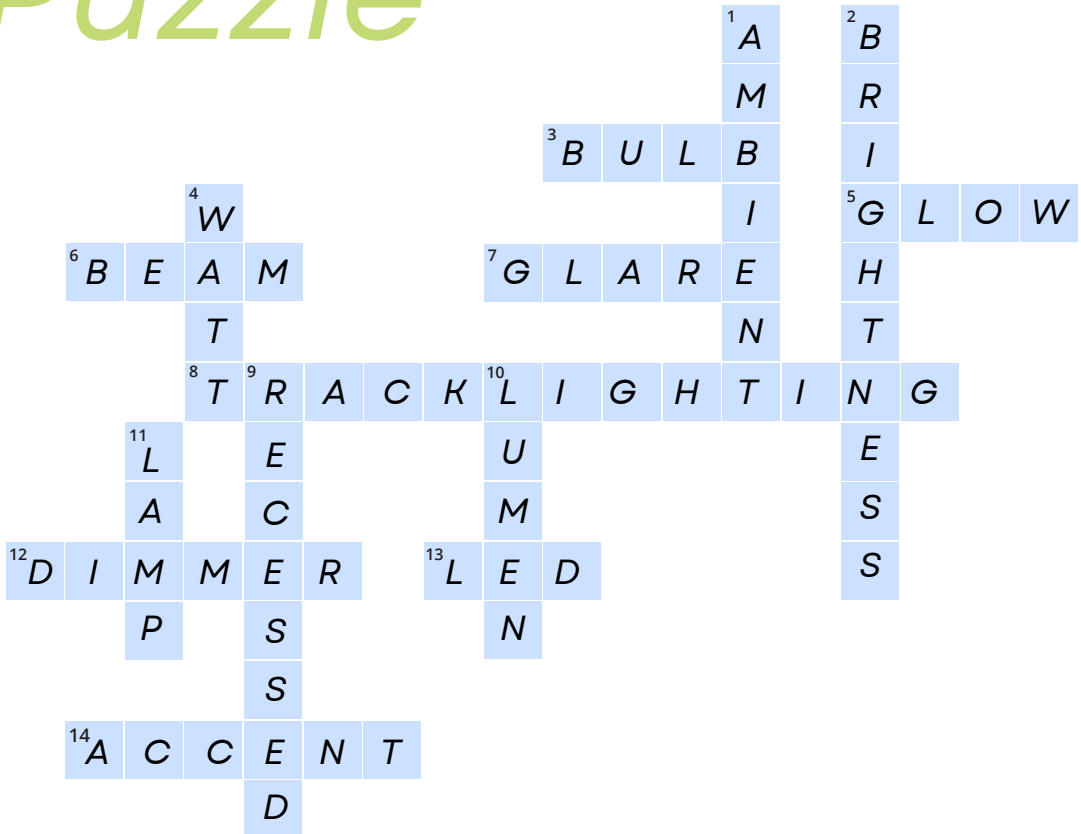

DOWN

1. General lighting that provides overall illumination.
2. An attribute of visual perception.
4. A measure of power consumption in a light source.
9. A light fixture set into a ceiling or wall.
10. A measure of how bright a light source is.
11. Another term for a light bulb or a complete light fixture.

ACROSS

3. The glass enclosure that produces light when powered.
5. A soft, steady light without glare.
6. A directed path of light from a source.
7. Harsh, bright light that causes discomfort.
8. A system where lights are attached to a continuous track.
12. A switch that adjusts brightness levels.
13. A long-lasting, energy-efficient type of light.
14. Lighting used to highlight specific areas or objects.

Crossword Puzzle

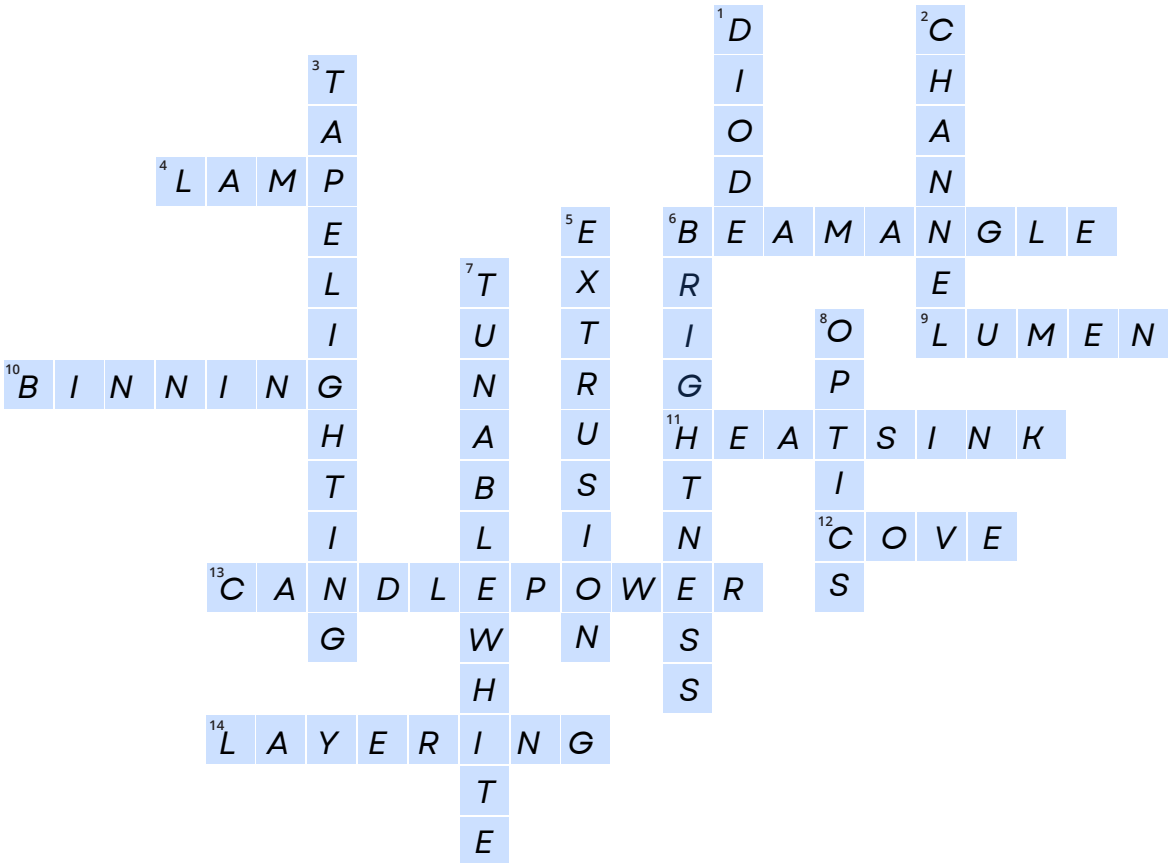

DOWN

1. LED, D.
2. Houses strip lighting.
3. Strip illumination.
4. An aluminum or plastic channel used to house and protect LED strips.
5. An attribute of visual perception.
7. A lighting feature that allows adjustment of color temperature.
8. The lens or reflector design that directs light output.

ACROSS

4. An alternative name for a light bulb.
6. The main spread of light emitted from a source, measured in degrees.
9. A measure of the total amount of visible light emitted from a source.
10. The process of sorting LEDs based on color and brightness consistency.
11. Dissipates excess energy efficiently.
12. An area of lighting usually built into ledges, recesses, or valences in ceilings.
13. Luminous intensity.
14. The term for using a combination of luminaires at different heights.

Lighting Word Search

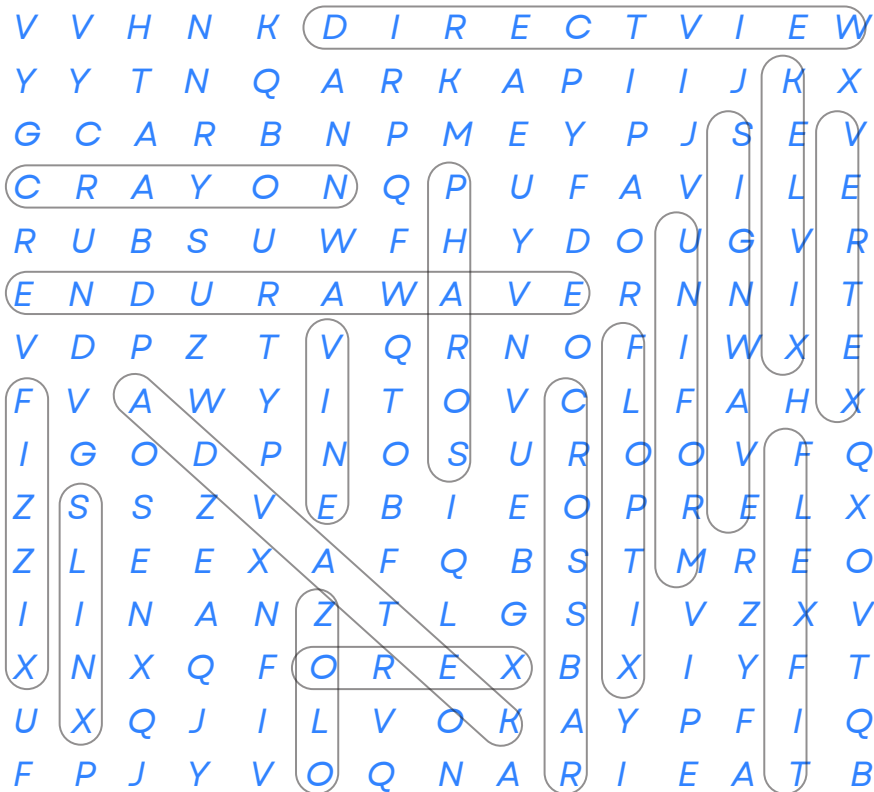

WORDS TO LOOK FOR

ENDURAWAVE
FLEXFIT
UNIFORM
SLINX
OREX
PHAROS
DIRECT VIEW
CROSSBAR
VERTEX
ZOLO
FIZZIX

SIGNWAVE
ADVATEK
FLOPTIX
CRAYON
KELVIX
VINE



